

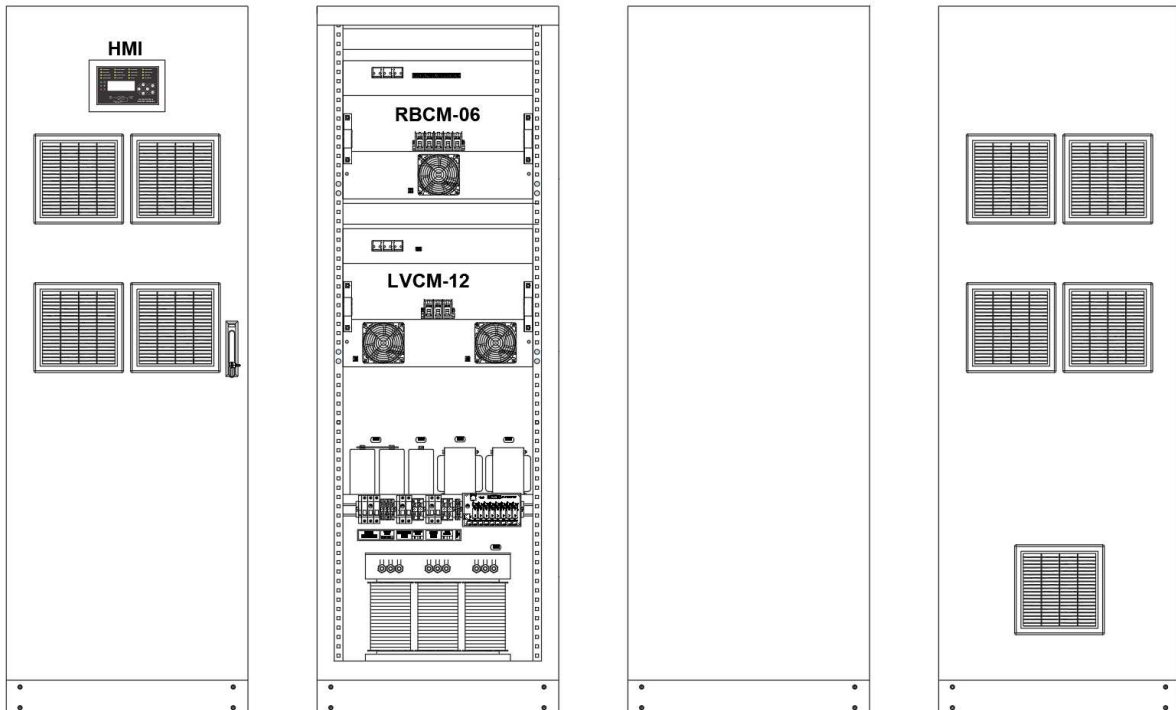

**WHITE PAPER FOR RBC-06 380VAC / 110VDC 100A
INDUSTRIAL BATTERY CHARGER
REV-10062022**



**380AC/110DC/100A
THREE PHASE BATTERY CHARGER DESIGN GUIDE
USING PESS RBCM-06 AND LVCM-12 POWER MODULES**

MAY 2022

AIM & SCOPE:

Main purpose of this paper is to be guide for battery charger producers to design a good quality three-phase industrial type battery charger product. This paper explains; how to design an example three-phase 6 pulse thyristor-switched galvanically-isolated battery charger rectifier with LVD and 2 stage dropper options, how to do wiring selections, MCB or MCCB selections, transformer and inductor design parameters, filter capacitor selections, cabinet selections and IP standards, how to use PESS power control modules, how to test battery charger products with technical specifications.

CONTENTS:

- 1) TRANSFORMER DESIGN GUIDE & EXAMPLE DESIGN
- 2) LC FILTER DESIGN GUIDE & EXAMPLE DESIGN
- 3) MCB/MCCB/CABLE SELECTION GUIDE & EXAMPLE
- 4) CABINET SELECTION GUIDE & IP STANDARTS
- 5) HOW TO USE PESS RECTIFIER AND LVCM POWER MODULE
- 6) HOW TO TEST BATTERY CHARGER WITH PESS RECTIFIER AND LVCM MODULE
- 7) PERFORMANCE TESTS

1. TRANSFORMER DESIGN GUIDE & EXAMPLE DESIGN

In this section we will explain to how you can the design a good quality three-phase 6 pulse rectifier transformer and calculations.

6 pulse transformers have a special structure because of its nature. It has 1 primary and 1 secondary windings. Figure 1.0 shows the physical structure of the 6 pulse transformer.

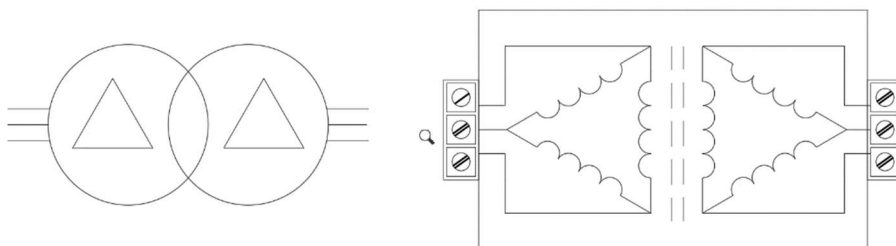

Figure 1.0. 6 pulse transformer structure.

1.1. Calculation of power transformer turn ratio

A three-phase rectifier output voltage versus input ac voltage can be define as eq.1.1;

$$V_{dc} = \frac{3 \times V_{max}}{\pi} = \frac{3\sqrt{2} \times V_{rms(ac)}}{\pi} \quad (1.1)$$

Because there is a step-down input isolation transformer at the input of rectifier, secondary voltage of transformer can be calculated as eq.1.2;

$$V_{rms(sec.)} = V_{dc} \times \frac{\pi}{3\sqrt{2}} = 0.75 \times V_{dc} \quad (1.2)$$

This voltage should be minimum secondary voltage at maximum allowable output voltage. A 110VDC battery charger has 122Vdc float and 128 Vdc boost voltage, sometimes this voltage can be 150Vdc. Thus, minimum secondary voltage of transformer should be in eq.1.3, and nominal secondary voltage should be in eq.1.4, and turn ratio is in eq.1.5.

$$V_{rms(sec.)}(min.) = 0.75 \times V_{dc} = 0.75 \times 150 = 113V_{ac} \quad (1.3)$$

$$V_{rms(sec.)}(nom.) = 1.15 \times V_{rms(sec.)}(min.) = 1.15 \times 113 = 130V_{ac} \quad (1.4),$$

if we consider 3 or 4 volts drop on the system, 133VAC is suitable for secondary voltage.

$$\frac{V_p}{V_s} = \frac{380}{133} = 2.85$$

(1.5)

1.2. Transformer design parameters

To produce a good quality three-phase / six pulse 380VAC/110VDC/100A battery charger, input isolation transformer of charger should be designed as follows. Table 1.1 shows the transformer design parameters, primary and secondary wiring details. Table 1.2 shows the core material details of transformer packet.

	Primary	Secondary
	Delta (Δ)	Delta (Δ)
Base Voltage	380V (Ph-Ph)	133V (Ph-Ph)
Power	16 KVA	16 KVA
Wire Area (cross section)	18.14 mm ² (Ø=3.4 mm)	49.23 mm ² (Ø=5.6 mm)
Wire Type	Aluminum Enamel	Aluminum Enamel
Turn	238 turns	84 turns

Table 1.1. Transformer Primary & Secondary Parameters

Material	iron core
Type	EI400
B(max)	10000 gauss (1 Tesla)
Ae	80 mm×90 mm (d) x (thickness)
Dimensions (EI400 packet)	400 mm×400 mm×90 mm (a) x (b+f) x (thickness)

Table 1.2. Transformer packet details, materials, dimensions.

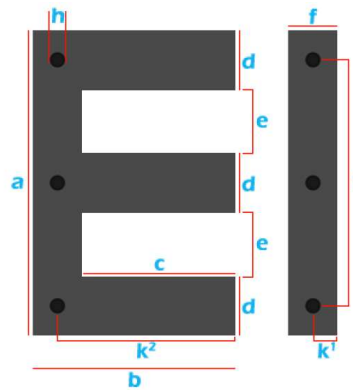

TRIFAZE EI Teknik Özellikleri

	a	b	c	d	e	f	h	i	k1	k2	kg/1000 0.5mm
EI 400x400 *	400	320	240	80	80	80	15	320	40	280	468

Figure 1.1. EI400 core datasheet details (All dimensions are *in millimeters)

Figure 1.1 shows the EI400 core material details.

- 1) One piece of this EI400 material is 468 gram and 0,5 mm thickness.
- 2) To get 90 mm thickness for transformer, it should be used 180 pieces.
- 3) To get good performance with transformer, it should be used, primary winding is outer, secondary wiring is inner, like as Figure 1.2.

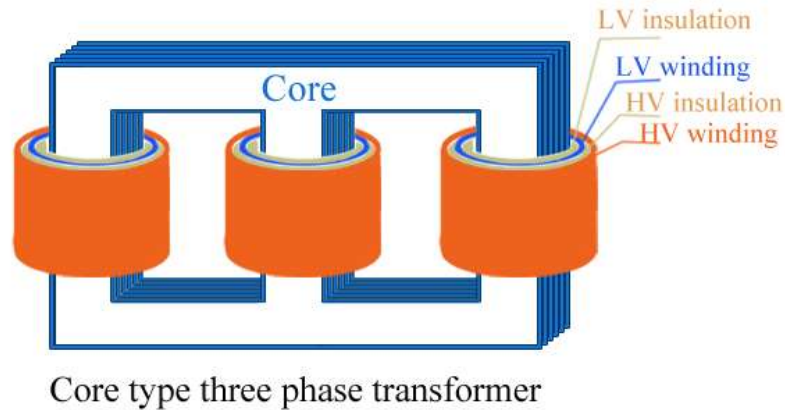

Figure 1.2. Three phase transformer winding details.

2. LC FILTER DESIGN GUIDE & EXAMPLE DESIGN

Output LC filter is necessary to achieve good ripple factor (RF) at the rectifier output. Capacitor should be selected as 20mF ($2 \times 10.000\text{UF}/200\text{V}$), and inductor value should be higher than 2mH to achieve ripple factor less than 1 percent. To make ripple factor lower than 1 percent is important for batteries. If ripple factor is bigger than 1 percent, batteries could see high ripple current and they may be fail.

2.1. Inductor design parameters

There is a output filter inductor as mention at above and this inductors should be identical. Following tables shows the inductor design parameters and wiring details. Table 2.2 shows the core material details of inductor packet.

Inductor Value	1.5 mH
Current	100A
Wire Area (cross section)	132.88 mm ² ($\varnothing=9.2$ mm)
Wire type	Copper Enamel
Turn	30 turns
Air gap	2 mm

Table 2.1. Output filter inductor & wiring parameters

Material	iron core
Type	EI250
B(max)	10000 gauss (1 Tesla)
Ae	83.3 mm×80 mm (d)x(thickness)
Core Dimensions (EI250 packet)	250mm×83.3 mm×80 mm a x (b+gap+f) x (thickness)

Table 2.2. Inductor packet details, materials, dimensions.

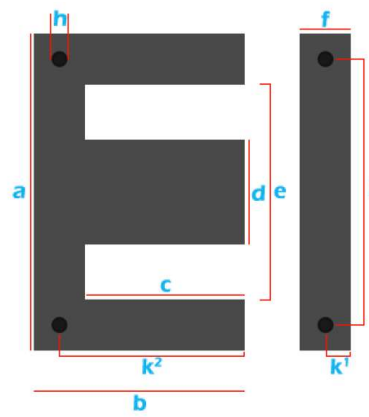

MONOFAZE EI Teknik Özellikleri

	a	b	c	d	e	f	h	i	k1	k2	kg/1000 0.5mm
EI 250	250	166,66	125	83,3	166,66	41,6	12	208,4	20,8	146,2	160,7

Figure 2.1. EI250 core datasheet details (All dimensions are *in millimeters)

Figure 2.1 shows the EI250 core material details.

- 1) One piece of this material (EI250) is 160.7 gram and 0,5 mm thickness.
- 2) To get 80 mm thickness for inductor, it should be used 160 pieces.
- 3) To get good performance with inductor, it should be used, with air gap like as Figure 2.2.

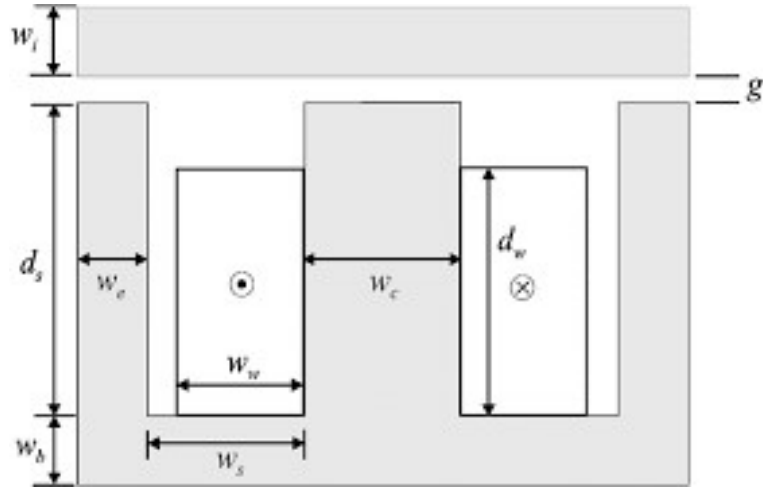

Figure 2.2. Output filter inductor winding and gap details for EI lamination.

3. MCB/MCCB/CABLE SELECTION GUIDE & EXAMPLE

MCB, MCCB and Wiring cables of rectifier should be selected properly to get secure performance. Example selection of 380AC/110VDC/100A charger can be seen the below in Table 3.1.

	AC side		DC side		
	Primer 380 VAC	DELTA 133 VAC	Inductor Capacitor	Battery Output	Load Output
POWER CABLES (NYAF COPPER)	10 mm ²	25 mm ²	35 mm ²	35 mm ²	35 mm ²
MCB	3×32A		-	2×100A	2×100A













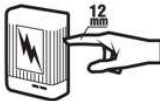

*All electronic cables (feedback, measurement and control) should be 0,75 mm² NYAF-type.

Table 3.1. 380AC/110VDC/100A battery charger MCB and cable selection table.

4. CABINET SELECTION GUIDE & IP STANDARTS

The IP Code (or Ingress Protection Rating, sometimes also interpreted as International Protection Rating) consists of the letters IP followed by two digits. First Numeral Protection against the ingress of solid particles and Second Numeral Protection against the harmful ingress of water

IP (Ingress Protection) Ratings Guide

SOLIDS		WATER	
1	 <p>Protected against a solid object greater than 50 mm such as a hand.</p>	1	 <p>Protected against vertically falling drops of water. Limited ingress permitted.</p>
2	 <p>Protected against a solid object greater than 12.5 mm such as a finger.</p>	2	 <p>Protected against vertically falling drops of water with enclosure tilted up to 15 degrees from the vertical. Limited ingress permitted.</p>
3	 <p>Protected against a solid object greater than 2.5 mm such as a screwdriver.</p>	3	 <p>Protected against sprays of water up to 60 degrees from the vertical. Limited ingress permitted for three minutes.</p>
4	 <p>Protected against a solid object greater than 1 mm such as a wire.</p>	4	 <p>Protected against water splashed from all directions. Limited ingress permitted.</p>
5	 <p>Dust Protected. Limited ingress of dust permitted. Will not interfere with operation of the equipment. Two to eight hours.</p>	5	 <p>Protected against jets of water. Limited ingress permitted.</p>
6	 <p>Dust tight. No ingress of dust. Two to eight hours.</p>	6	 <p>Water from heavy seas or water projected in powerful jets shall not enter the enclosure in harmful quantities.</p>
<p>Rating Example:</p> <p>IP65</p> <p>INGRESS PROTECTION</p>		7	 <p>Protection against the effects of immersion in water between 15 cm and 1 m for 30 minutes.</p>
		8	 <p>Protection against the effects of immersion in water under pressure for long periods.</p>

5. HOW TO USE PESS RECTIFIER AND LVCM POWER MODULES

The main advantage of PESS rectifier power module is to make easy to produce battery charger products for suppliers. PESS rectifier power module contains all necessary power electronic control equipment like PCB, thyristor blocks, heatsinks, fan, user panel, communication panel etc. Using PESS rectifier power module, any suppliers can produce their own battery charger cabinets. All necessary equipment except PESS rectifier power module could be assembled as offshore in supplier side, like cabinet, transformer, inductor, capacitor, power wirings, MCB etc. A PESS rectifier power module comes with user HMI front panel, Automation relay and communication board and two DC current sensor.



Figure 5.1. PESS RECTIFIER POWER CONTROL MODULE

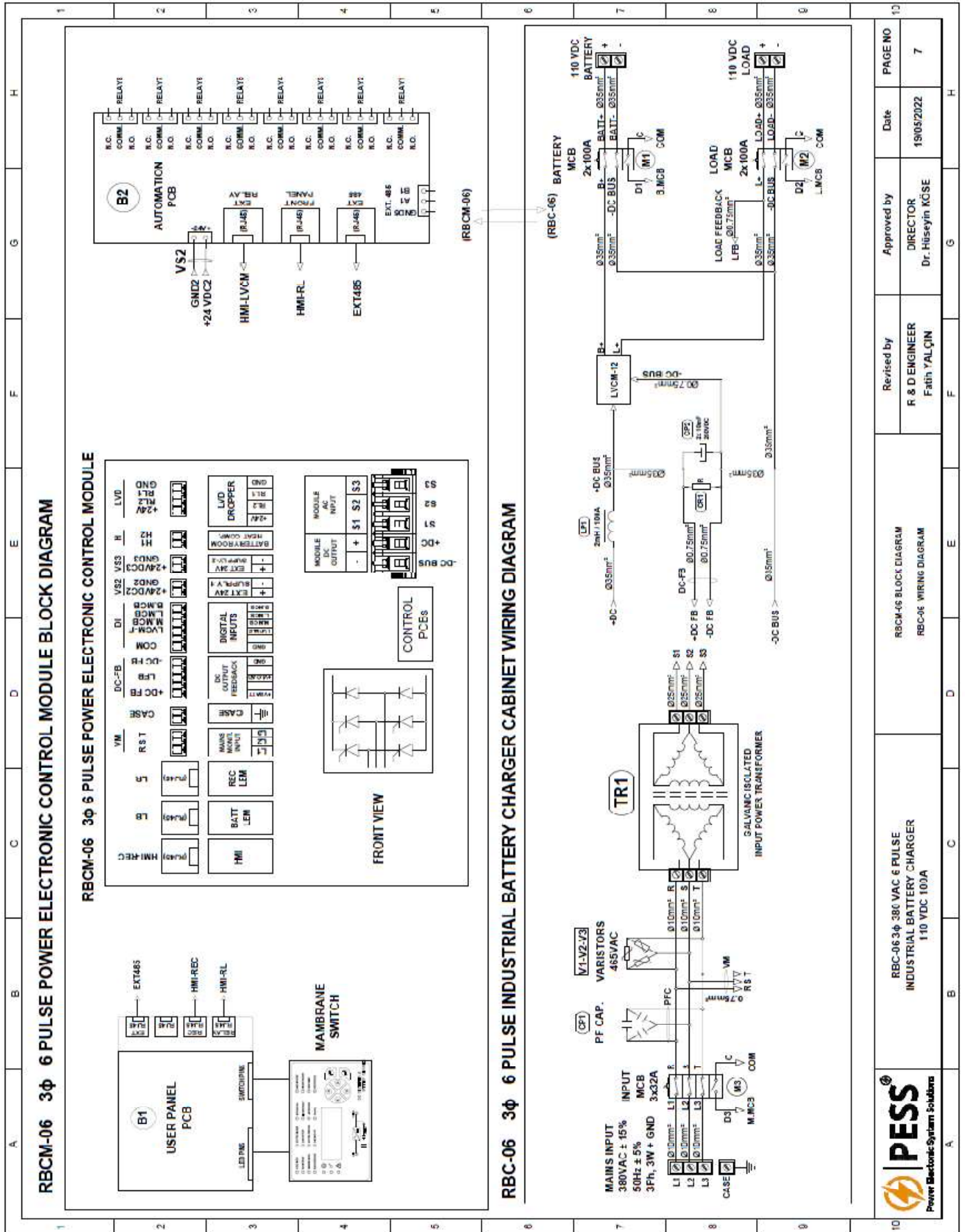

Figure 5.2. PESS LVCM POWER CONTROL MODULE

5.1. Connections of PESS RECTIFIER and LVCM Power Modules

PESS rectifier power module terminals consists of AC power inputs, DC power outputs to LC filter, AC voltage monitoring input from the primary of transformer, DC voltage feedback input from DC capacitors, two LEM DC current sensor input from the battery and load lines, digital inputs from MCB auxiliary contacts, thermistor input from battery room, 24VDC supply output for relay board and one more 24VDC supply output for extra cabinet fan.

Single-line diagrams (SLD), sample battery charger power wirings, module wirings can be seen from wiring documents that comes with power module. Basic diagram about power module and charger wiring can be seen in Figure 5.3 and Figure 5.4.



10	A	B	C	D	E	F	Revised by	Approved by	Date	PAGE NO
							R & D ENGINEER Fatih YALÇIN	DIRECTOR Dr. Hüseyin KİSE		
RBCM-06 BLOCK DIAGRAM RBC-06 WIRING DIAGRAM										
RBC-06 3φ 380 VAC 6 PULSE INDUSTRIAL BATTERY CHARGER 110 VDC 100A										

Figure 5.3.

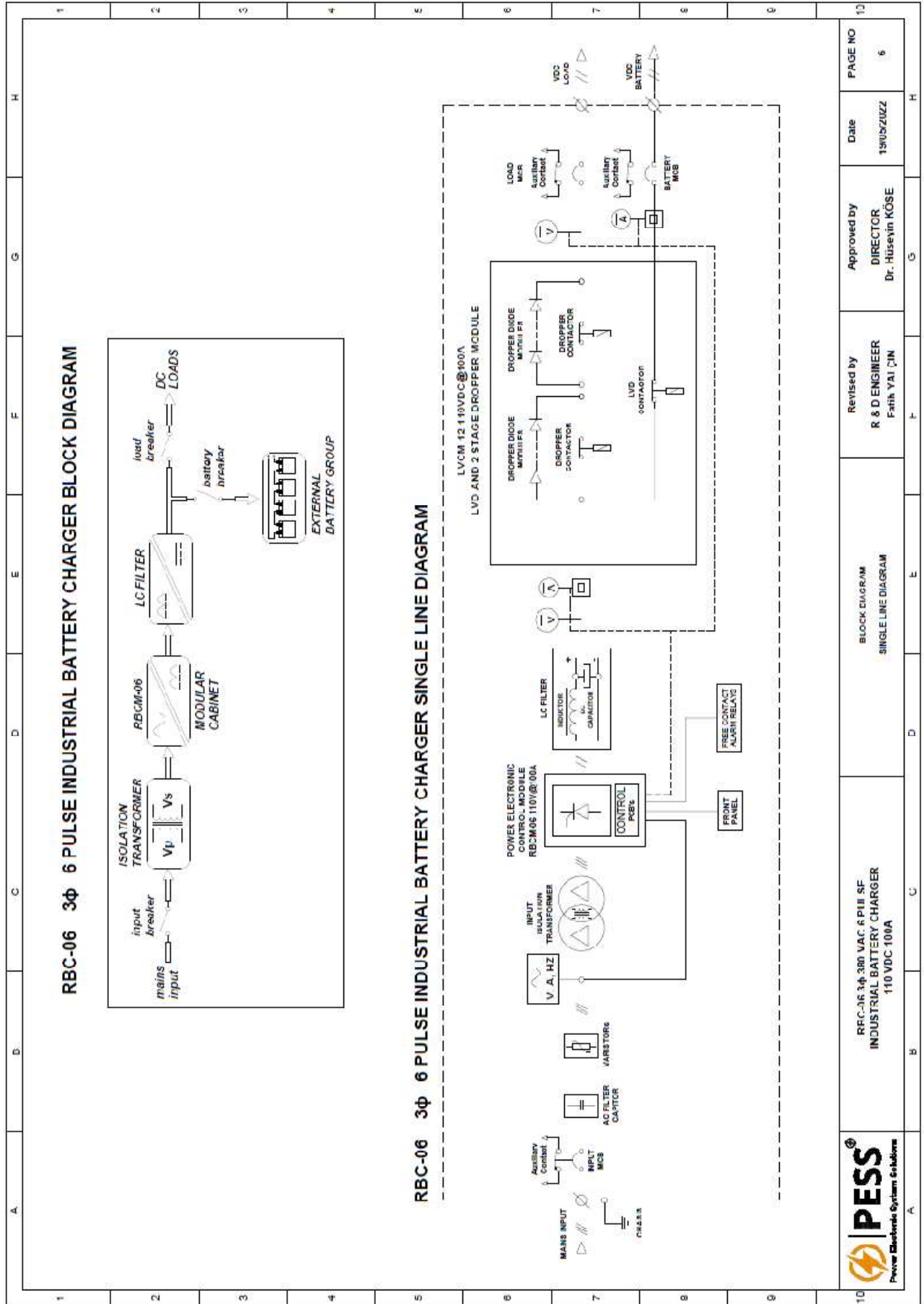

RBC-06 3φ 380 VAC 6 PUL SF
INDUSTRIAL BATTERY CHARGER
110 VDC 100A

BLOCK DIAGRAM
SINGLE LINE DIAGRAM

Approved by
DIRECTOR
Dr. Hüseyin KOSE

Date
19/05/2022

PAGE NO
6

Figure 5.4.

6. HOW TO TEST BATTERY CHARGER WITH PESS RECTIFIER MODULE

6.1. How to test Power Module

It is the most important procedure for producing battery charger product. PESS rectifier power modules come with user HMI panel, relay PCB and two LEM current sensors. All power modules are tested at factory.

6.2. Transformer Synchronous Connection Check

Transformer output voltage should be checked before install. One of important part before the energize system, find out synchronous phases between transformer primary/secondary. Sometimes transformer manufacturers may be connect phase coils randomly. Please ensure that transformer phase order and connections is correct !

6.3. Test Steps

Check all the connection again according to wiring diagram!!!

Step 1: Disconnect DC output cables (+/-) from module.

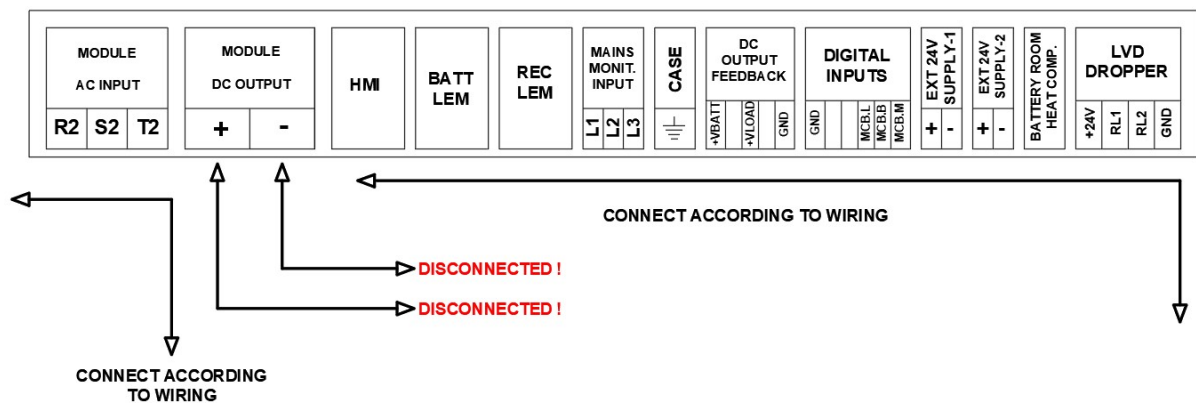

Step 2: Energize system from input breaker and check input and output voltage and current values on HMI front Panel.

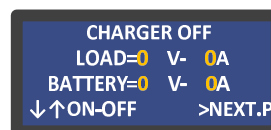
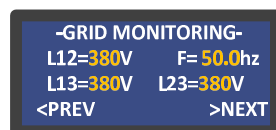

After you observe values shown above **Turn OFF input breaker**. (Any different situation for values you should check wiring and connections again).

Step 3: If there is any misconnection or wrong sequence to input, there may be a false working for thyristor triggering, so that there may be an explosion for output LC capacitors.

Because of this risk, there is a resistor test method for initial stating the rectifier. Please connect a 1k/400W or 470R/400W resistor across between +DC and -DC connection terminal as a parallel. Test resistor setup is shown below.

This test resistor will limit the current and you can see thyristor pulses are true or not.

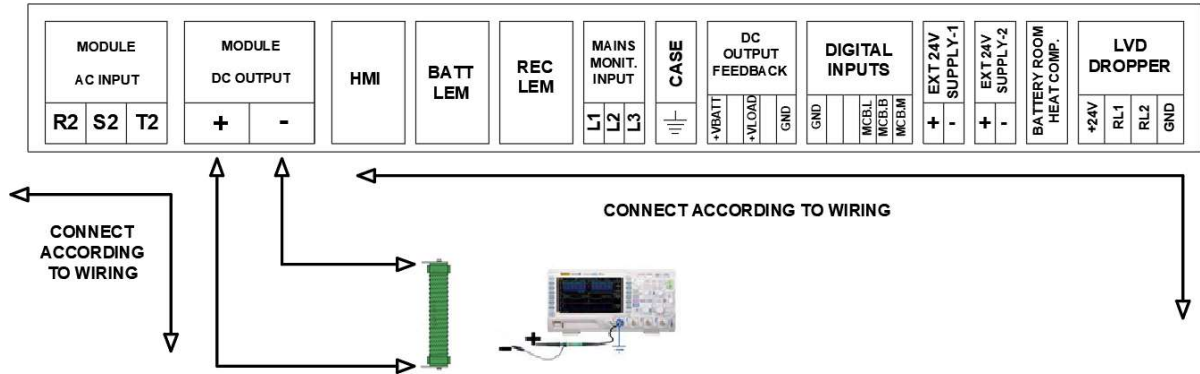

Step 4: Set oscilloscope parameters volt/div 100V, time/div 5ms and trigger

- Turn ON input breaker and keep looking oscilloscope screen to observe soft start and similar view below.
- If you observe soft start and oscilloscope screen **Turn OFF input breaker**.

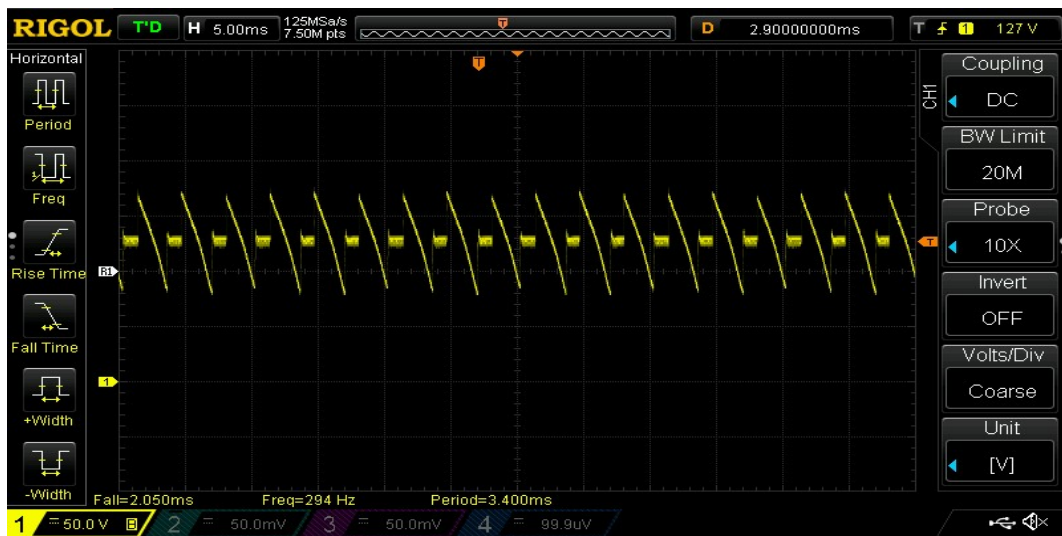

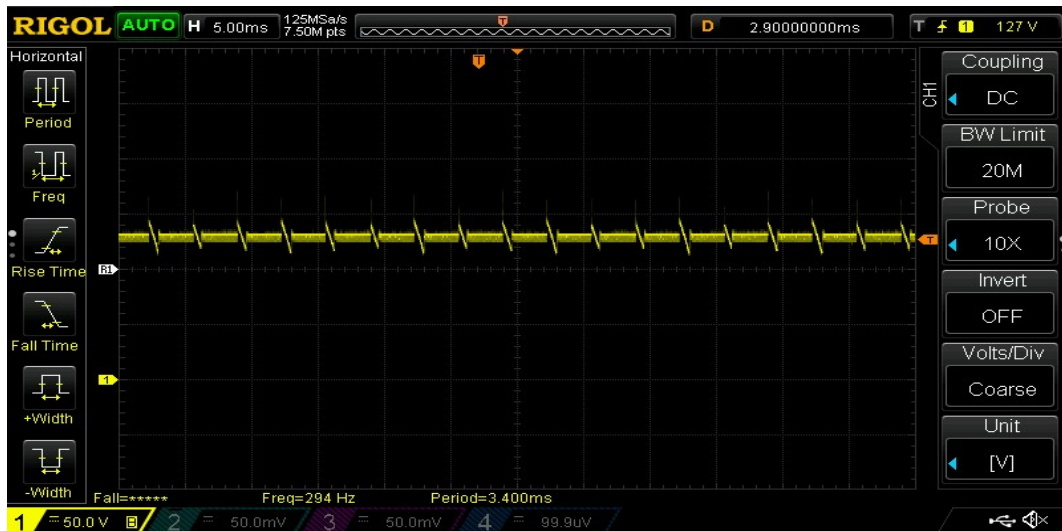

!!! If you cannot observe soft-start and similar view above this means there is a synchronous problem to input, this situation caused by “transformer output” or “mains monitoring input” connection. Go to “Transformer Synchronous Connection Check” again or check “mains monitoring input” connection sequence according to wiring!!!

Step 5: Disconnect test resistor and connect directly +DC Cable to the module then turn ON input breaker. You will observe

same screen on HMI Front panel also you can connect a multimeter or oscilloscope output of rectifier.

```

CHARGER ON
LOAD=122.4V- 0A
BATTERY=122.4V- 0A
↓↑ON-OFF >NEXT.P
  
```

Step 6: Connect battery group and Load to the system.

Load %100 percent and check Rectifier Current Module from HMI front panel.

```

CHARGER ON
LOAD=122.4V-60A
BATTERY=122.4V- 0A
↓↑ON-OFF >NEXT.P
  
```

Turn OFF system and check Battery Current Module from HMI front panel.

```

CHARGER OFF
LOAD=118V- 60A
BATTERY=118V- -60A
↓↑ON-OFF >NEXT.P
  
```

Step 7: Turn ON system again and wait with load until Cooling Fans are started.

After these steps and rectifier connection test, module connection test and initializing procedures will be completed successfully.

6.4. LVCM-12 Power Electronic Control Module

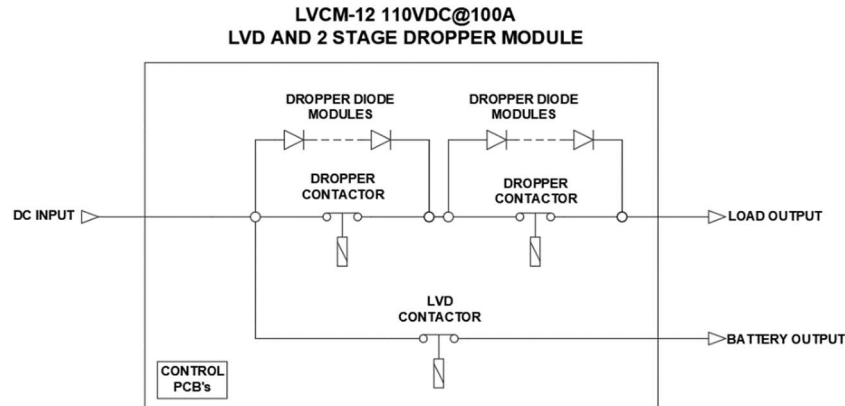

LVCM-12 is LVD and 2 stage Dropper Power Electronic Control Module. Connection of the LVCM-12 module is located in figure 5.3. LVCM-12 always fix the load voltage at the nominal value when the rectifier module charges the batteries therefore loads protect against from high charge voltage.

Dropper diodes are only connected to the load line when the grid is available and rectifier charge the batteries. Therefore, dropper diode current rating is selected according to the continues 100A load current ratings.

But if the grid is not available dropper diodes are disabled by dropper contactors and load supply provide from batteries.

$$\frac{122VDC}{100A} = 1.22\Omega \text{ min load resistance}$$

if the grid is not available DC BUS voltage is max 110VDC min 80 VDC (supply from batteries)

$$\frac{110VDC}{1.22\Omega} = 90A \text{ max current drained from batteries}$$

$$\frac{80VDC}{1.22\Omega} = 65A \text{ min current drained from batteries}$$

LVD and dropper contactor is selected according to these calculations result.

Also LVCM-12 module has LVD(Low Voltage Disconnect) ability therefore when the rectifier module detect the battery ending situation, batteries disconnect from system by LVD protection system.

When any abnormal condition or malfunction situation has occurred, Rectifier module detect this situation and inform the user over HMI module.

Detectable situations :

- Electronic control fail
- Communication Error
- Over temperature

7.PERFORMANCE TESTS

7.1. Ripple Factor Test

To test ripple factor of rectifier, A true rms multimeter (like Fluke) should be connected to load-MCB terminals (+, -). Multimeter reads the DC voltage and AC voltage between the connected terminals. Ripple factor of the rectifier should be less than (1%) percent to get good-filtered harmless DC voltage for batteries (at full load).

$$RF = (Vac(rms))/VDC (rms)) \times 100 (\%) \quad (7.1)$$

- This test should be done without battery and for all load conditions from 10% to 100% (at 380 Vac input).
- DC voltage ripple will be better with battery, but without battery RF is the real parameter to get as reference.

7.2. Input Voltage Limits Test

- To test input voltage acceptable limits for rectifier working, connect a variac to input of rectifier.
- Input voltage acceptable limits are important to get technical specifications for critical area. Full load working limits are tested with this voltage limit test. So that, this test should be done at full load, without battery.
- Open input MCB with 380 Vac input voltage, see the rectifier soft-start and going float voltage, open load MCB and give some loads 10%. Increase the load step by step up to 100%. In these steps battery MCB should be closed.
- At full load, play the variac and set the variac 380 Vac -15% = 325 Vac, and 380 Vac + 15% = 445 Vac, see the workings.
- Out of these acceptable limits, rectifier will stop working, and returning the acceptable limits rectifier starts automatically.
- Out of these voltage limits, rectifier will give line failure alarm, thick led will disappear, but there is a failure alarm, after retuning normal voltages, rectifier will work, thick led will appear and line failure alarms will disappear.

7.3. Current limits test

- Other specific test is current limitation test for rectifiers. PESS rectifier power module allows two current limitations, one is at the rectifier output as total output DC current, other is at the battery side to limit battery charge / discharge current.
- It can be tested easily with 380 Vac input conditions. Connect the load, open the load MCB when rectifier floating without battery.
- Give some loads, and increase the loads up to see current limit led appear on HMI and check the pens-ammeter current reding on load side.

- To test battery charge current limits, open the battery MCB at full-load, and close the input MCB for discharge battery, after some discharging about 2 minutes, close the load MCB, and open the input MCB again, see the current limit led appears on HMI and check the pen-ammeter reading on battery side.

7.4. Power Factor Testing

- Power factor testing should be done nominal conditions; where input is 380 Vac, without battery and at full load.
- Connect a power analyzer to input of rectifier, in power reading mode, check the VA, W, PF readings at nominal input conditions without battery and full load.

7.5. Calibration of voltage, current readings on HMI

There isn't any potentiometer on the anywhere of PESS rectifier modules. All measurements are made by high precision (%1 tolerance) components. However, if the customer's need to calibrate any values on HMI Module, all calibrations can be made over communication channel between PC and HMI Module. You can see the relevant section at the Figure 7.1 in the yellow squared section



Figure 7.1.