



WHITE PAPER RBCM-6P 380AC/110DC/60A

REV.01



380AC/110DC/60A

THREE-PHASE BATTERY CHARGER DESIGN GUIDE

USING PESS RECTIFIER POWER MODULE

OCTOBER 2022

AIM & SCOPE:

Main purpose of this paper is to be guide for battery charger producers to design a good quality three-phase industrial type battery charger product. This paper explains; how to design an example battery charger three-phase thyristor-switched galvanically-isolated battery charger rectifier, how to do wiring selections, MCB or MCCB selections, transformer and inductor design parameters, filter capacitor selections, cabinet selections and IP standards, how to use PESS rectifier power control module, how to test battery charger products with technical specifications.

CONTENTS:

- 1) TRANSFORMER DESIGN GUIDE & EXAMPLE DESIGN
- 2) LC FILTER DESIGN GUIDE & EXAMPLE DESIGN
- 3) MCB/MCCB/CABLE SELECTION GUIDE & EXAMPLE
- 4) CABINET SELECTION GUIDE & IP STANDARTS
- 5) HOW TO USE PESS RECTIFIER POWER MODULE
- 6) HOW TO TEST BATTERY CHARGER WITH PESS RECTIFIER MODULE
- 7) PERFORMANCE TESTS

1. TRANSFORMER DESIGN GUIDE & EXAMPLE DESIGN

To design a good quality galvanically-isolated input power transformer for three-phase rectifier, following calculations and design parameters are helpful. First important thing is to define transformer turn ratio to get maximum output specs ever in minimum input conditions.

1.1. Calculation of power transformer turn ratio

A three-phase rectifier output voltage versus input ac voltage can be define as eq.1.1;

$$V_{dc} = \frac{3 \times V_{max}}{\pi} = \frac{3\sqrt{2} \times V_{rms(ac)}}{\pi} \quad (1.1)$$

Because there is a step-down input isolation transformer at the input of rectifier, secondary voltage of transformer can be calculated as eq.1.2;

$$V_{rms(sec.)} = V_{dc<max>} \times \frac{\pi}{3\sqrt{2}} = 0.75 \times V_{dc} \quad (1.2)$$

This voltage should be minimum secondary voltage at maximum allowable output voltage. A 110VDC battery charger has 122Vdc float and 128 Vdc boost voltage, sometimes this voltage can be 150Vdc. Thus, minimum secondary voltage of transformer should be in eq.1.3, and nominal secondary voltage should be in eq.1.4, and turn ratio is in eq.1.5.

$$V_{rms(sec.)<min.>} = 0.75 \times V_{dc} = 0.75 \times 150 = 113V_{ac} \quad (1.3)$$

$$V_{rms(sec.)<nom.>} = 1.15 \times V_{rms(sec.)<min.>} = 1.15 \times 113 = 130V_{ac} \quad (1.4),$$

Thus; 133VAC selected for secondary.

$$\frac{V_p}{V_s} = \frac{380}{133} = 2.85 \quad (1.5)$$

1.2. Transformer design parameters

To produce a good quality three-phase / six pulse 380VAC/110VDC/60A battery charger, input isolation transformer of charger should be designed as follows. Table 1.1 shows the transformer design parameters, primary and secondary wiring details. Table 1.2 shows the core material details of transformer packet.

| | Primary | Secondary |
|---------------------------|---------------------------------------|-------------------------------------|
| Connection | Delta (Δ) | Delta (Δ) |
| Base Voltage | 380V (Ph-Ph) | 133V (Ph-Ph) |
| Power | 10 KVA | 10 KVA |
| Wire Area (cross section) | 5.5 mm ² ($\phi=2,60$ mm) | 16 mm ² ($\phi=4,5$ mm) |
| Wire Type | Aluminum Enamel | Aluminum Enamel |
| Turn | 306 turns | 108 turns |

Table 1.1. Transformer Primary & Secondary Parameters

| | |
|---------------------------|--|
| Material | iron core |
| Type | EI350 |
| B(max) | 10000 gauss (1 Tesla) |
| Ae | 70 mm×80 mm (d) x (thickness) |
| Dimensions (EI350 packet) | 350 mm×350 mm×80 mm (a) x (b+f) x (thickness) |

Table 1.2. Transformer packet details, materials, dimensions.

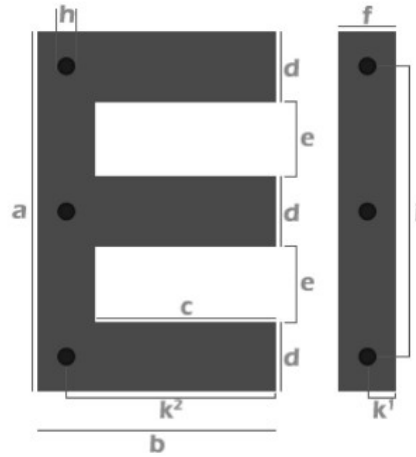

TRIFAZE EI Teknik Özellikleri

| | a | b | c | d | e | f | h | i | k1 | k2 | kg/1000 0.5mm |
|--------------|-----|-----|-----|----|----|----|----|-----|----|-----|------------------|
| EI 350x350 * | 350 | 280 | 210 | 70 | 70 | 70 | 15 | 280 | 35 | 245 | 356 |

Figure 1.1. EI350 core datasheet details (All dimensions are *in millimeters)

Figure 1.1 shows the EI350 core material details.

- 1) One piece of this EI350 material is 356 gram and 0,5 mm thickness.
- 2) To get 80 mm thickness for transformer, it should be used 160 pieces.
- 3) To get good performance with transformer, it should be used, primary winding is outer, secondary wiring is inner, like as Figure 1.2.

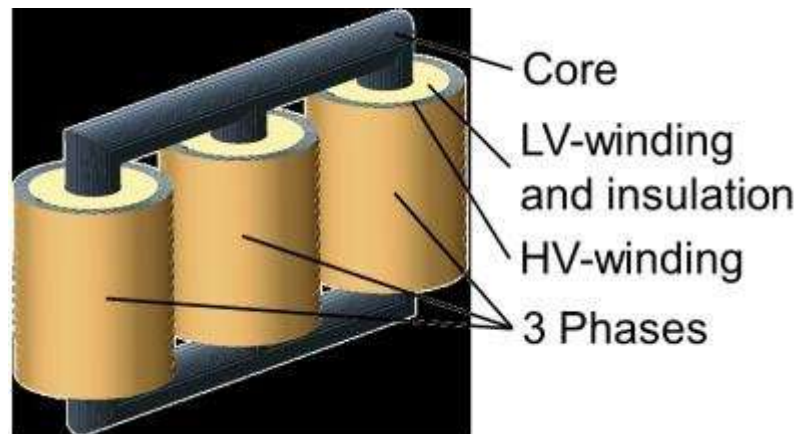

Figure 1.2. Three phase transformer winding details.

2. LC FILTER DESIGN GUIDE & EXAMPLE DESIGN

Output LC filter is necessary to achieve good ripple factor (RF) at the rectifier output. Capacitor should be selected as 20mF (2 x 10.000UF/200V), and inductor value should be higher than 2mH to achieve ripple factor less than 1 percent. To make ripple factor lower than 1 percent is important for batteries. If ripple factor is bigger than 1 percent, batteries could see high ripple current and they may fail.

2.1. Inductor design parameters

To produce a good quality three-phase 380VAC/110VDC/60A battery charger, output filter inductor of charger should be designed as follows. Table 2.1 shows the inductor design parameters and wiring details. Table 2.2 shows the core material details of inductor packet.

| | |
|---------------------------|-----------------------------|
| Inductor Value | 2 mH |
| Current | 60A |
| Wire Area (cross section) | 20 mm ² (Ø=5 mm) |
| Wire type | Copper Enamel |
| Turn | 32 turns |
| Air gap | 2 mm |

Table 2.1. Output filter inductor & wiring parameters

| | |
|-----------------------------------|---|
| Material | iron core |
| Type | EI146 |
| B(max) | 10000 gauss (1 Tesla) |
| Ae | 41.4 mm×80 mm (d)x(thickness) |
| Core Dimensions (EI146 packet) | 146mm×110 mm×80 mm a x (b+gap+f) x (thickness) |

Table 2.2. Inductor packet details, materials, dimensions.

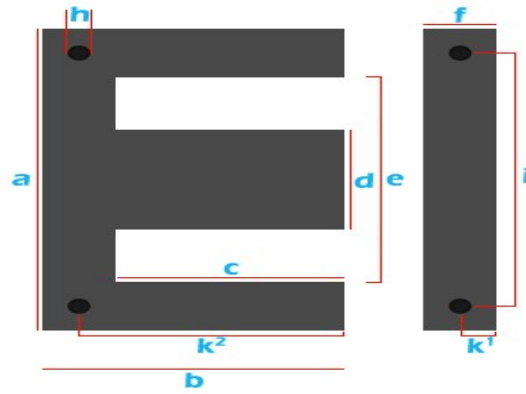

MONOFAZE EI Teknik Özellikleri

| | a | b | c | d | e | f | h | i | k1 | k2 | kg/1000 0.5mm |
|--------|-----|------|------|------|-------|------|-----|-------|------|----|------------------|
| EI 146 | 146 | 87.3 | 66.7 | 41.4 | 104.8 | 20.6 | 5.5 | 125.4 | 10.3 | 77 | 44,4 |

Figure 2.1. E146 core datasheet details (All dimensions are *in millimeters)

Figure 2.1 shows the E146 core material details.

- 1) One piece of this material (E146) is 44,4 gram and 0,5 mm thickness.
- 2) To get 80 mm thickness for inductor, it should be used 160 pieces.
- 3) To get good performance with inductor, it should be used, with air gap like as Figure 2.2.

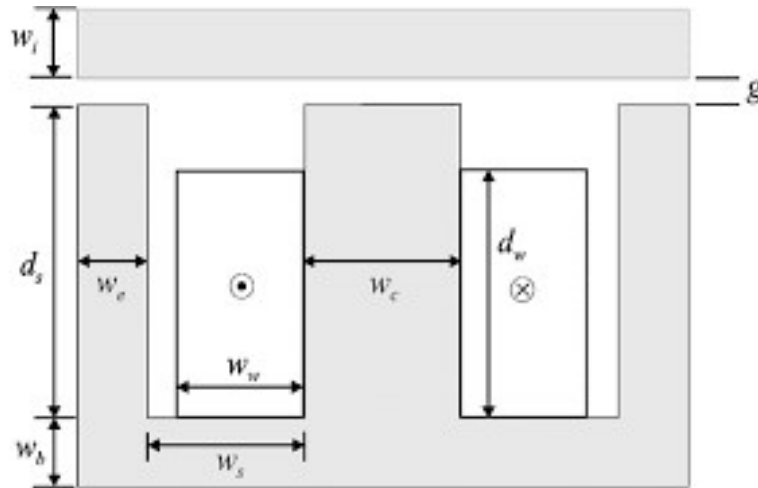

Figure 2.2. Output filter inductor winding and gap details for EI lamination.

3. MCB/MCCB/CABLE SELECTION GUIDE & EXAMPLE

MCB, MCCB and Wiring cables of rectifier should be selected properly to get secure performance. Example selection of 380AC/110VDC/60A charger can be seen the below in Table 3.1.

| | AC side | | DC side | | |
|---------------------------------------|--------------------|---------------------|-----------------------|--------------------|--------------------|
| | Primer 380 VAC | Seconder 133 VAC | Inductor Capacitor | Battery Output | Load Output |
| POWER CABLES (NYAF COPPER) | 10 mm ² | 16 mm ² | 25 mm ² | 16 mm ² | 16 mm ² |
| MCB | 3×25A | - | - | 2×63A | 2×63A |

*All electronic cables (feedback, measurement and control) should be 0,5 mm² NYAF-type.







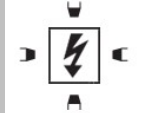

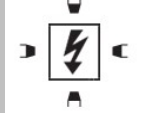

Table 3.1. 380AC/110VDC/60A battery charger MCB and cable selection table.

4. CABINET SELECTION GUIDE & IP STANDARTS

The IP Code (or Ingress Protection Rating, sometimes also interpreted as International Protection Rating) consists of the letters IP followed by two digits. First Numeral Protection against the ingress of solid particles and Second Numeral Protection against the harmful ingress of water

First Number

Second Number

| IP | Requirement | Example | Protection of human | IP | Requirement | Example | Protection from water |
|----|--|---|---------------------|----|---|---|--|
| 0 | No protection | | Non-protected | 0 | No protection | | Non-protected |
| 1 | Full penetration of 50mm diameter sphere not allowed. Contact with hazardous parts not permitted. |  | Back of hand | 1 | Protected against vertically falling drops of water. Limited ingress permitted. |  | Vertically dripping |
| 2 | Full penetration of 12.5 mm diameter sphere not allowed. The jointed test finger shall have adequate clearance from hazardous parts. |  | Finger | 2 | Protected against vertically falling drops of water with the enclosure tilted 15° from the vertical. Limited ingress permitted. |  | Dripping up to 15° from the vertical |
| 3 | The access probe of 2.5 mm diameter shall not penetrate. |  | Tool | 3 | Protected against sprays to 60° from the vertical. Limited ingress permitted. | | Limited spraying |
| 4 | The access probe of 1.0 mm diameter shall not penetrate. |  | Wire | 4 | Protected against water splashed from all directions. Limited ingress permitted. | | Splashing from all directions |
| 5 | Limited ingress of dust permitted (no harmful deposit). |  | Wire | 5 | Protected against jets of water. Limited ingress permitted. |  | Hosing jets from all directions |
| 6 | Totally protected against the ingress of dust. |  | Wire | 6 | Protected against strong jets of water. Limited ingress permitted. |  | Strong hosing jets from all directions |
| | | | | 7 | Protected against the effects of immersion between 15cm and 1m. |  | Temporary immersion |
| | | | | 8 | Protected against long periods of immersion under pressure |  | Continuous immersion |

5. HOW TO USE PESS RECTIFIER POWER MODULE

The main advantage of PESS rectifier power module is to make easy to produce battery charger products for suppliers. PESS rectifier power module contains all necessary power electronic control equipment like PCB, thyristor blocks, heatsinks, fan, user panel, communication panel etc. Using PESS rectifier power module, any suppliers can produce their own battery charger cabinets. All necessary equipment except PESS rectifier power module could be assembled as off-shore in supplier side, like cabinet, transformer, inductor, capacitor, power wirings, MCB etc. A PESS rectifier power module comes with user HMI front panel, Automation relay and communication board and two DC current sensor as seen Figure 5.1

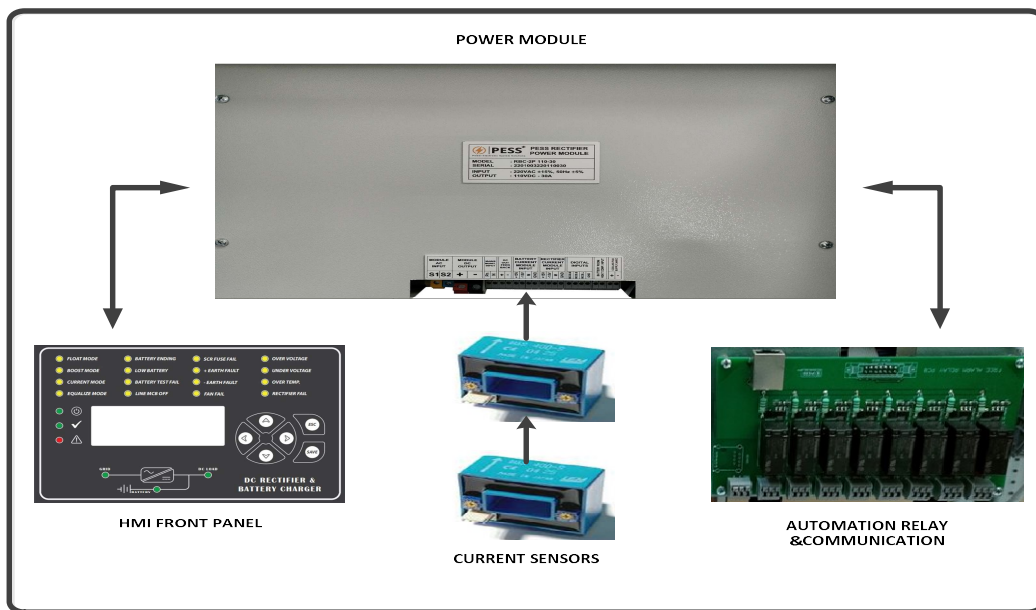

Figure 5.1.

5.1. Connections of PESS rectifier power module

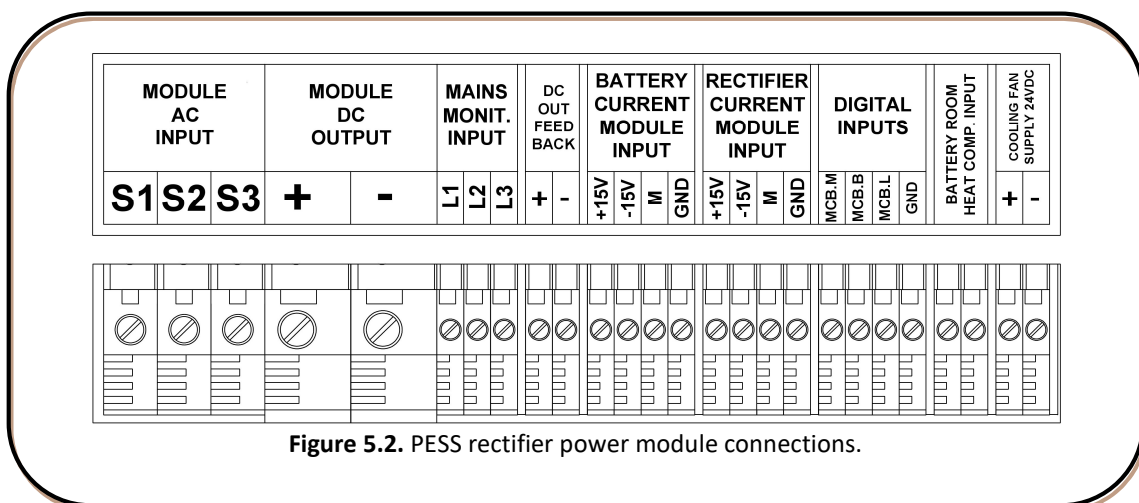

Figure 5.2. PESS rectifier power module connections.

PESS rectifier power module terminals and connections can be seen in Figure 5.2. It consists of AC power inputs, DC power outputs to LC filter, AC voltage monitoring input from the primary of transformer, DC voltage feedback input from DC capacitors, two LEM DC current sensor input from the battery and load lines, digital inputs from MCB free contacts, thermistor input from battery room, 24VDC supply output for extra cabinet fan.

Single-line diagrams (SLD), sample battery charger power wirings, module wirings can be seen from wiring documents that comes with power module. Basic diagram about power module and charger wiring can be seen in Figure 5.3 and Figure 5.4.

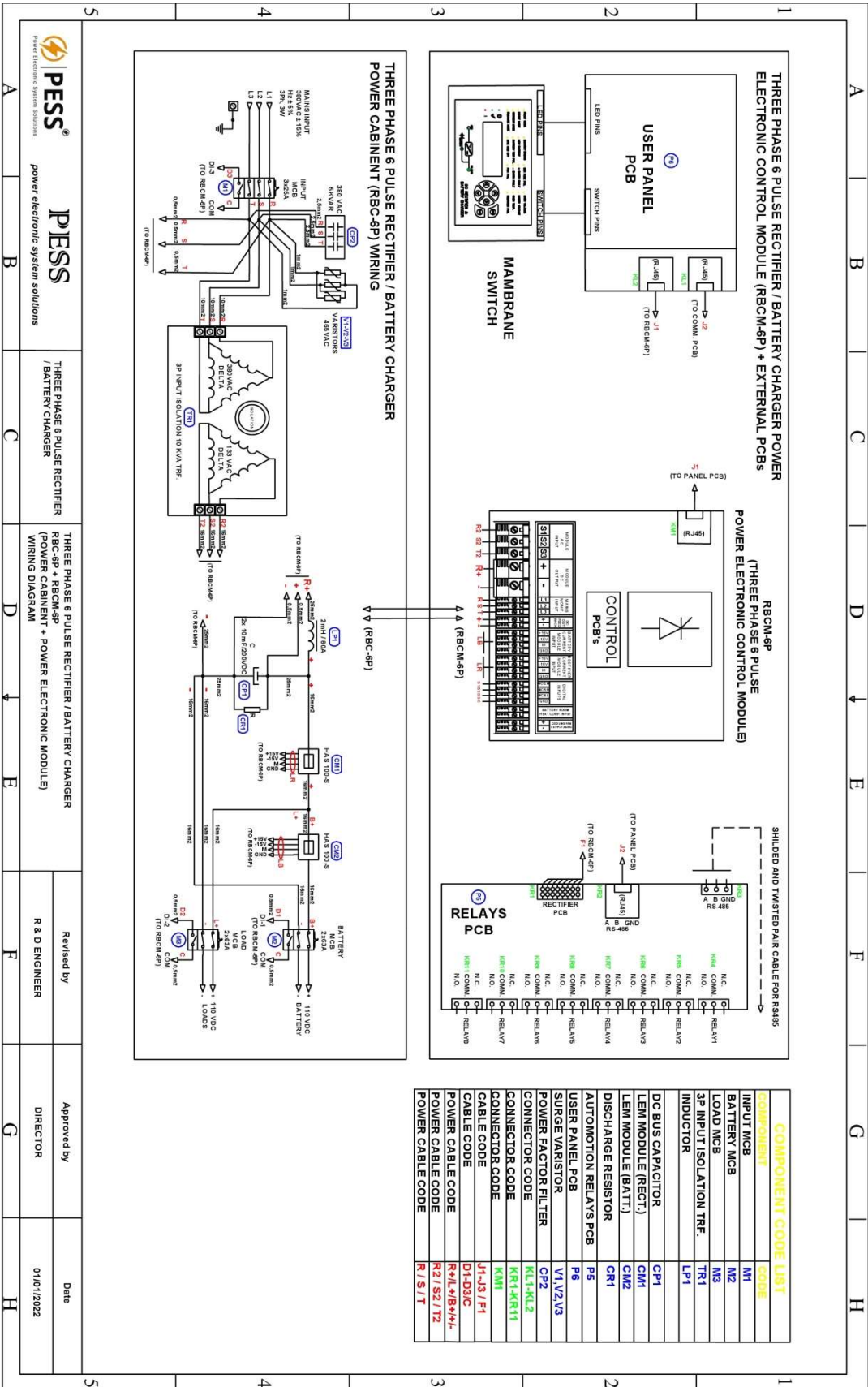

Figure 5.3.

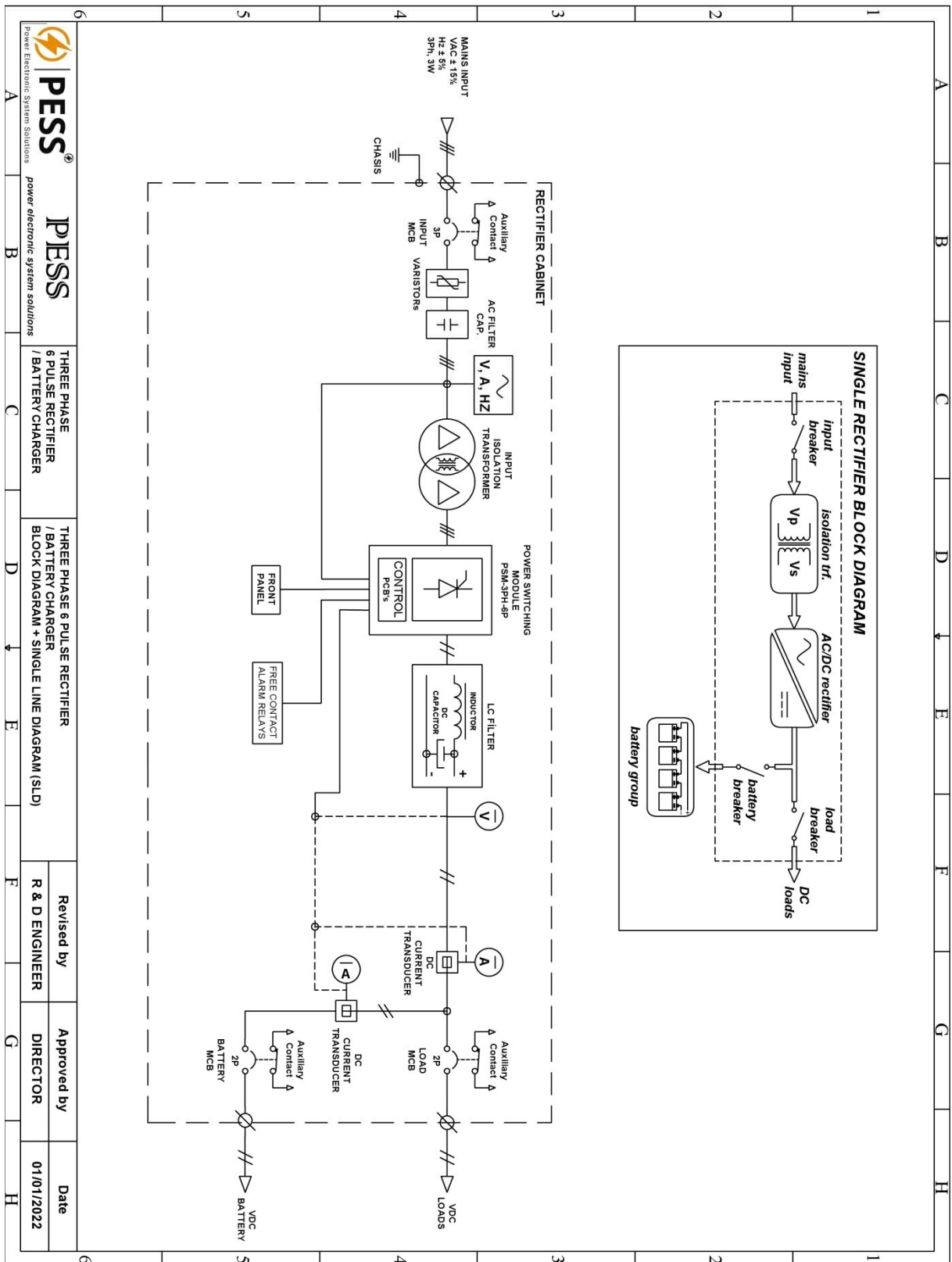

Figure 5.4.

| | | | | | |
|---|---|---|------------------------------|-------------------------|--------------------|
| PESS power electronic system solutions | THREE PHASE 6 PULSE RECTIFIER / BATTERY CHARGER | THREE PHASE 6 PULSE RECTIFIER / BATTERY CHARGER BLOCK DIAGRAM + SINGLE LINE DIAGRAM (SLD) | Revised by R & D ENGINEER | Approved by DIRECTOR | Date 01/01/2022 |
| | Power Electronic System Solutions | | | | |

6. HOW TO TEST BATTERY CHARGER WITH PESS RECTIFIER MODULE

6.1. How to test Power Module

It is the most important procedure for producing battery charger product. PESS rectifier power modules come with user HMI panel, relay PCB and two LEM current sensors. All power modules are tested at factory.

6.2. Transformer Synchronous Connection Check

Transformer output voltage should be checked before install. (Input 380VAC P-P/Output 133VAC P-P)

One of important part before energize system, find out synchronous phases between transformer primary/secondary. Transformer manufacturers can connect coils random. For synchronous control, energize primary of transformer (380VAC P-P) and check one phase from primary other phases from secondary with a AC meter. The phase with lowest voltage value means to synchronous to input phase. Please look example below;

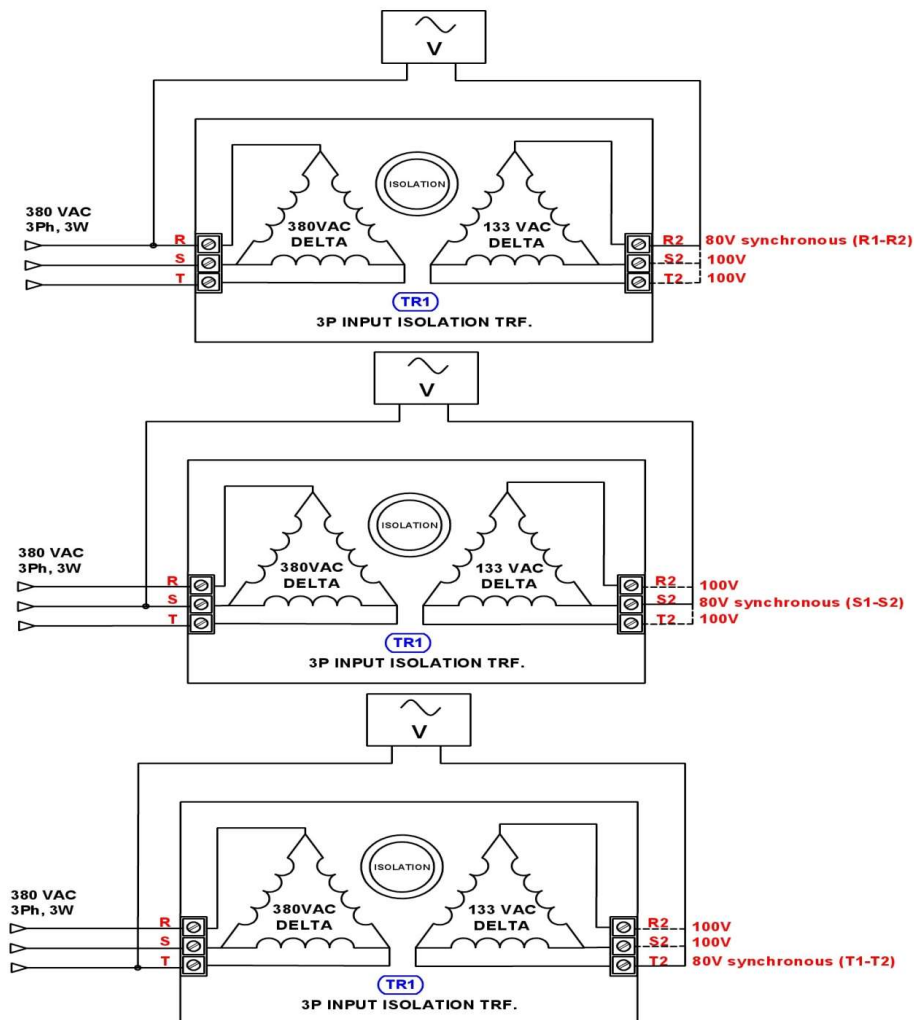

Note: Values can be different on your application but lowest valued measurement at secondary side to input means that phases synchronous.

6.3. Test Steps

Check all the connection again according to wiring diagram!!!

Step 1: Disconnect DC output + cable from module.

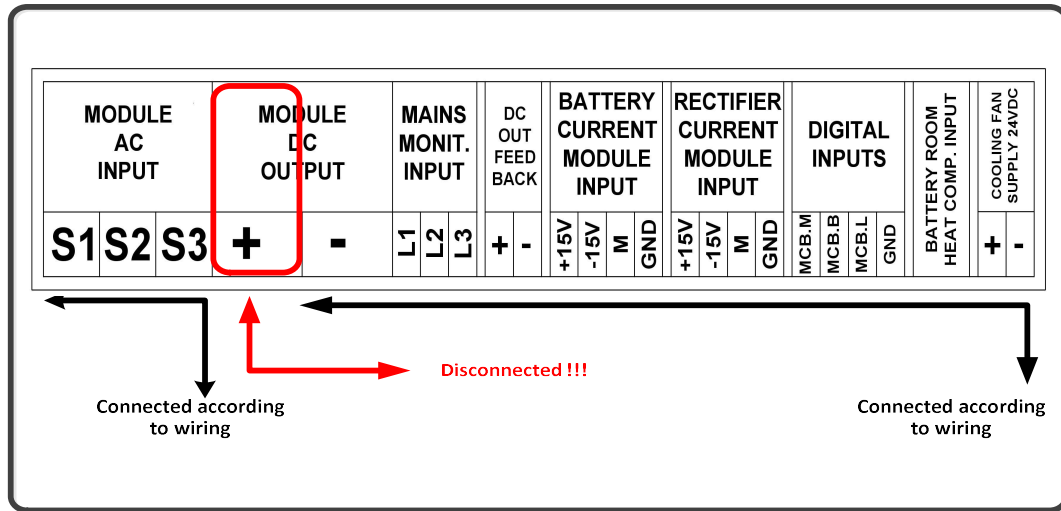

Step 2: Energize system from input breaker and check input and output voltage and current values on HMI front Panel.

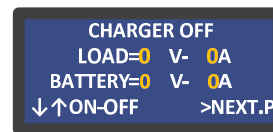
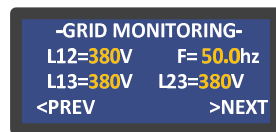

After you observe values shown above **Turn OFF input breaker**. (Any different situation for values you should check wiring and connections again).

Step 3: If there is any misconnection or wrong sequence to input, there may be a false working for thyristor triggering, so that there may be an explosion for output LC capacitors.

Because of this risk; there is a resistor test method for initial stating the rectifier. Please connect a 1k/400W or 470R/400W resistor between 'R+' point as series. Test resistor setup is shown below.

This test resistor will limit the current and you can see thyristor pulses are true or not.

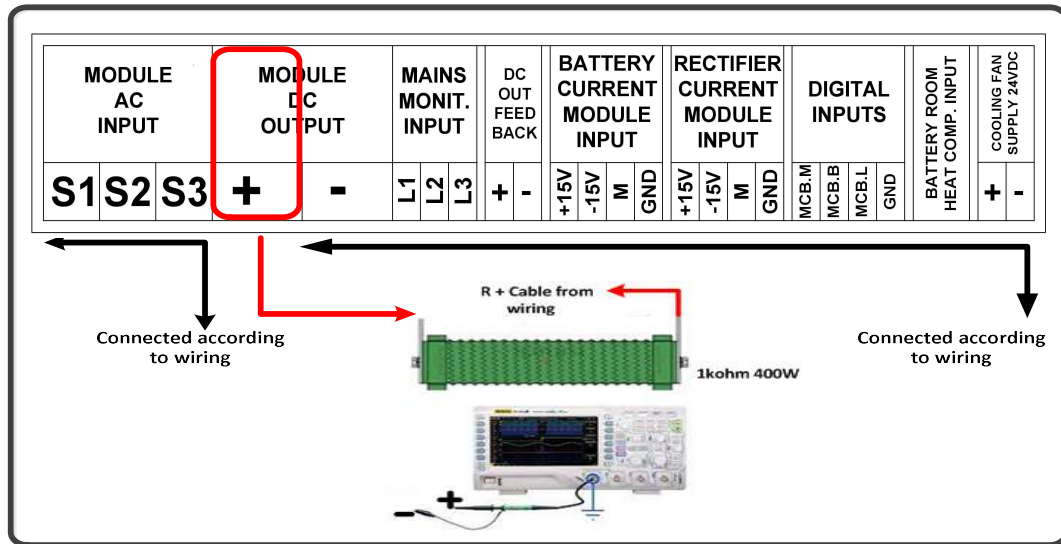

Step 4: Set oscilloscope parameters volt/div 100V, time/div 5ms and trigger

- Turn ON input breaker and keep looking oscilloscope screen to observe soft start and similar view below.
- If you observe soft start and oscilloscope screen **Turn OFF input breaker.**

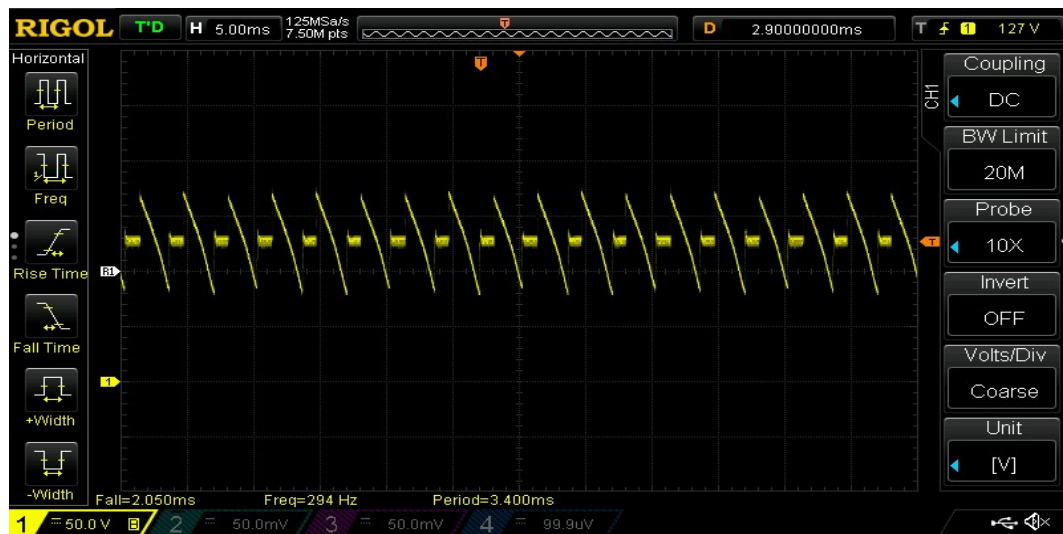

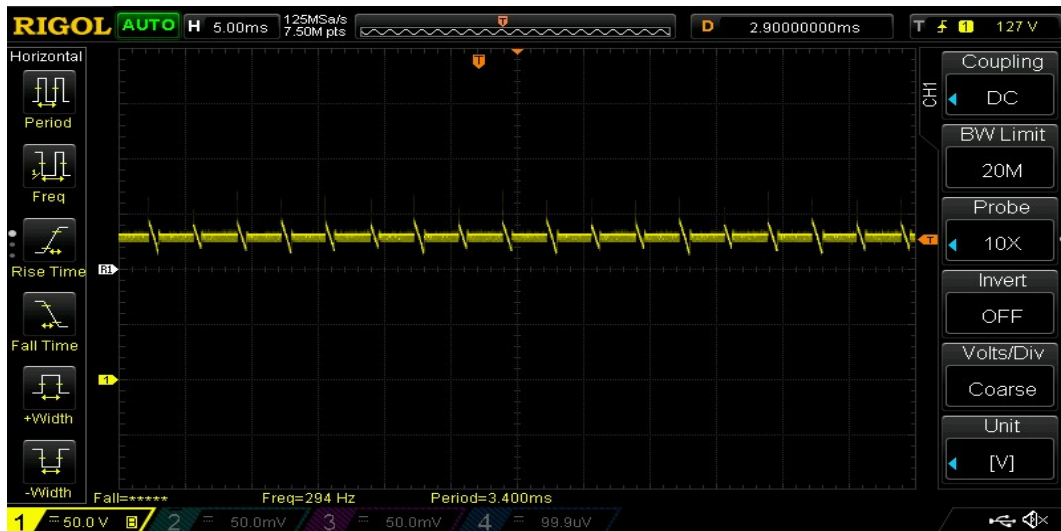

!!! If you cannot observe soft-start and similar view above this means there is a synchronous problem to input, this situation caused by “transformer output” or “mains monitoring input” connection. Go to “Transformer Synchronous Connection Check” again or check “mains monitoring input” connection sequence according to wiring!!!

Step 5: Disconnect test resistor and connect directly R+ Cable to the module then turn ON input breaker. You will observe

same screen on HMI Front panel also you can connect a multimeter or oscilloscope output of rectifier.

```

CHARGER ON
LOAD=122.4V- 0A
BATTERY=122.4V- 0A
↓↑ON-OFF >NEXT.P
  
```

Step 6: Connect battery group and Load to the system.

Load %100 percent and check Rectifier Current Module from HMI front panel.

```

CHARGER ON
LOAD=122.4V-60A
BATTERY=122.4V- 0A
↓↑ON-OFF >NEXT.P
  
```

Turn OFF system and check Battery Current Module from HMI front panel.

```

CHARGER OFF
LOAD=118V- 60A
BATTERY=118V- -60A
↓↑ON-OFF >NEXT.P
  
```

Step 7: Turn ON system again and wait with load until Cooling Fans are started.

After these steps and rectifier connection test, module connection test and initializing procedures will be completed successfully.

7.PERFORMANCE TESTS

7.1. Ripple Factor Test

To test ripple factor of rectifier, A true rms multimeter (like Fluke) should be connected to load-MCB terminals (+, -). Multimeter reads the DC voltage and AC voltage between the connected terminals. Ripple factor of the rectifier should be less than (1%) percent to get good-filtered harmless DC voltage for batteries (at full load).

$$RF = (Vac(rms))/VDC (rms)) \times 100 (\%) \quad (7.1)$$

- This test should be done without battery and for all load conditions from 10% to 100% (at 380 Vac input).
- DC voltage ripple will be better with battery, but without battery RF is the real parameter to get as reference.

7.2. Input Voltage Limits Test

- To test input voltage acceptable limits for rectifier working, connect a variac to input of rectifier.
- Input voltage acceptable limits are important to get technical specifications for critical area. Full-load working limits are tested with this voltage limit test. So that, this test should be done at full-load, without battery.
- Open input MCB with 380 Vac input voltage, see the rectifier soft-start and going float voltage, open load MCB and give some loads 10%. Increase the load step by step up to 100%. In these steps battery MCB should be closed.
- At full load, play the variac and set the variac 380 Vac -15% = 325 Vac, and 380 Vac + 15% = 445 Vac, see the workings.
- Out of these acceptable limits, rectifier will stop working, and returning the acceptable limits rectifier starts automatically.
- Out of these voltage limits, rectifier will give line failure alarm, thick led will disappear, but there is a failure alarm, after retuning normal voltages, rectifier will work, thick led will appear and line failure alarms will disappear.

7.3. Current limits test

- Other specific test is current limitation test for rectifiers. PESS rectifier power module allows two current limitations, one is at the rectifier output as total output DC current, other is at the battery side to limit battery charge / discharge current.
- It can be tested easily with 380 Vac input conditions. Connect the load, open the load MCB when rectifier floating without battery.
- Give some loads, and increase the loads up to see current limit led appear on HMI and check the pens-ammeter current reding on load side.
- To test battery charge current limits, open the battery MCB at full-load, and close the input MCB for discharge battery, after some discharging about 2 minutes, close the load MCB, and

open the input MCB again, see the current limit led appears on HMI and check the pen-ammeter reading on battery side.

7.4. Power Factor Testing

- Power factor testing should be done nominal conditions; where input is 380 Vac, without battery and at full-load.
- Connect a power analyzer to input of rectifier, in power reading mode, check the VA, W, PF readings at nominal input conditions without battery and full-load.

7.5. Calibration of voltage, current readings on HMI

There is no potentiometer on PCBS or anywhere of PESS rectifier module. All measurements are made with standardized components and 1% error components. However; if customer needs to calibrate any readings on HMI, they can do all calibrations from PC with communication over PC HMI. It can be seen below in Figure 7.1 from the yellow squared area.

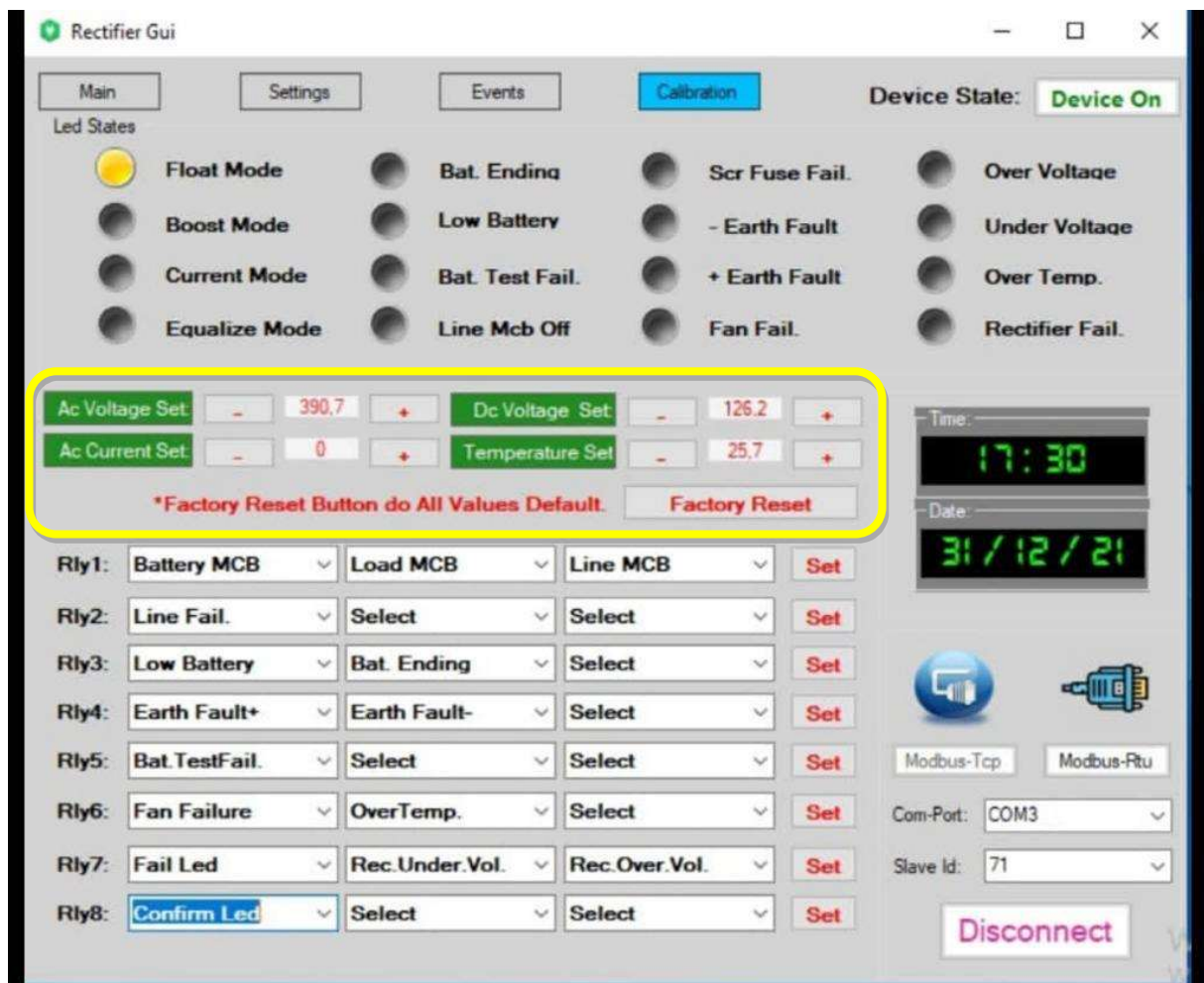

Figure 7.1.